

Part #17479

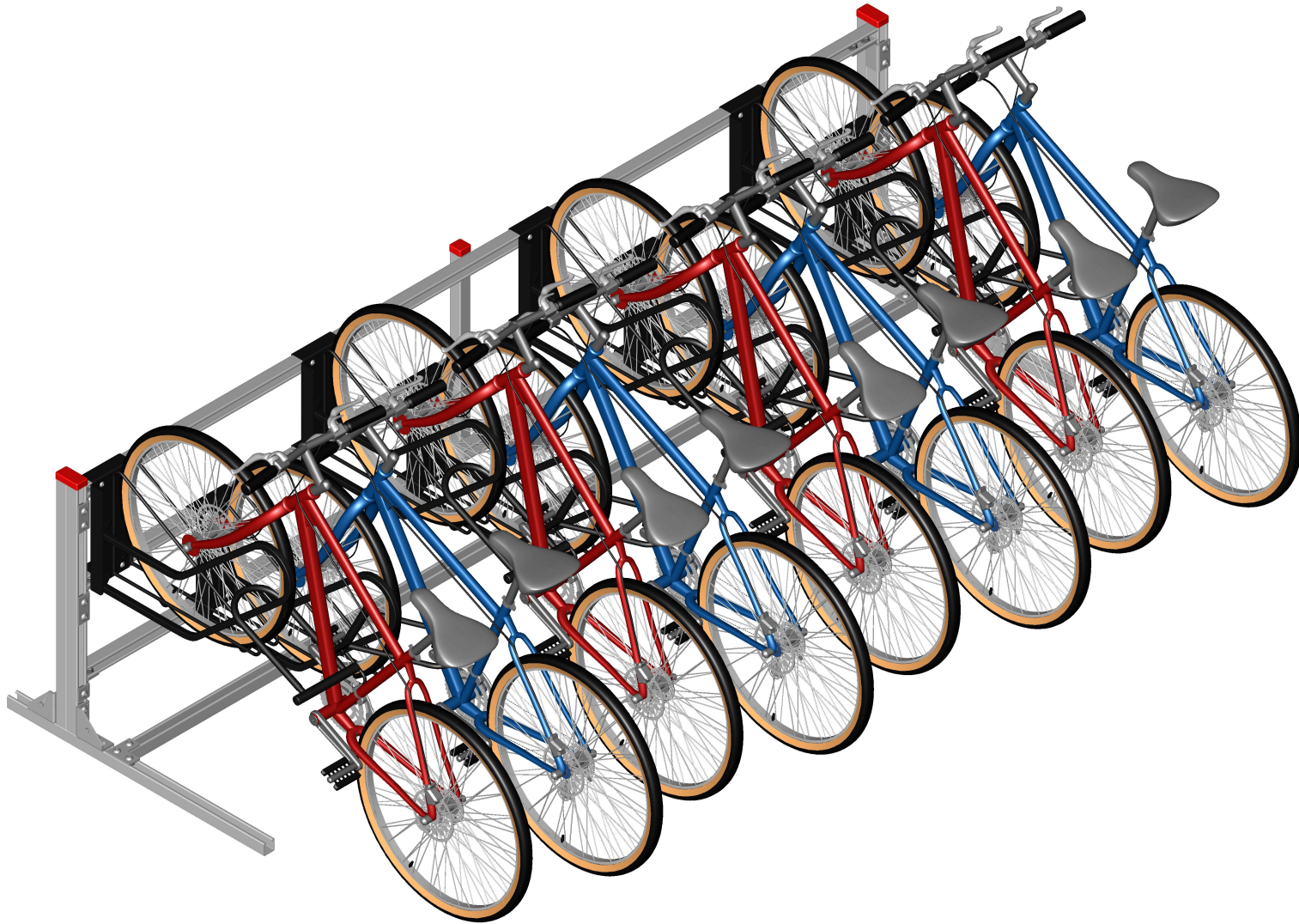

Bike Stall {8-Bike} U-Strut  
Strut Base {Straight} Master {Iso}

Part #17479

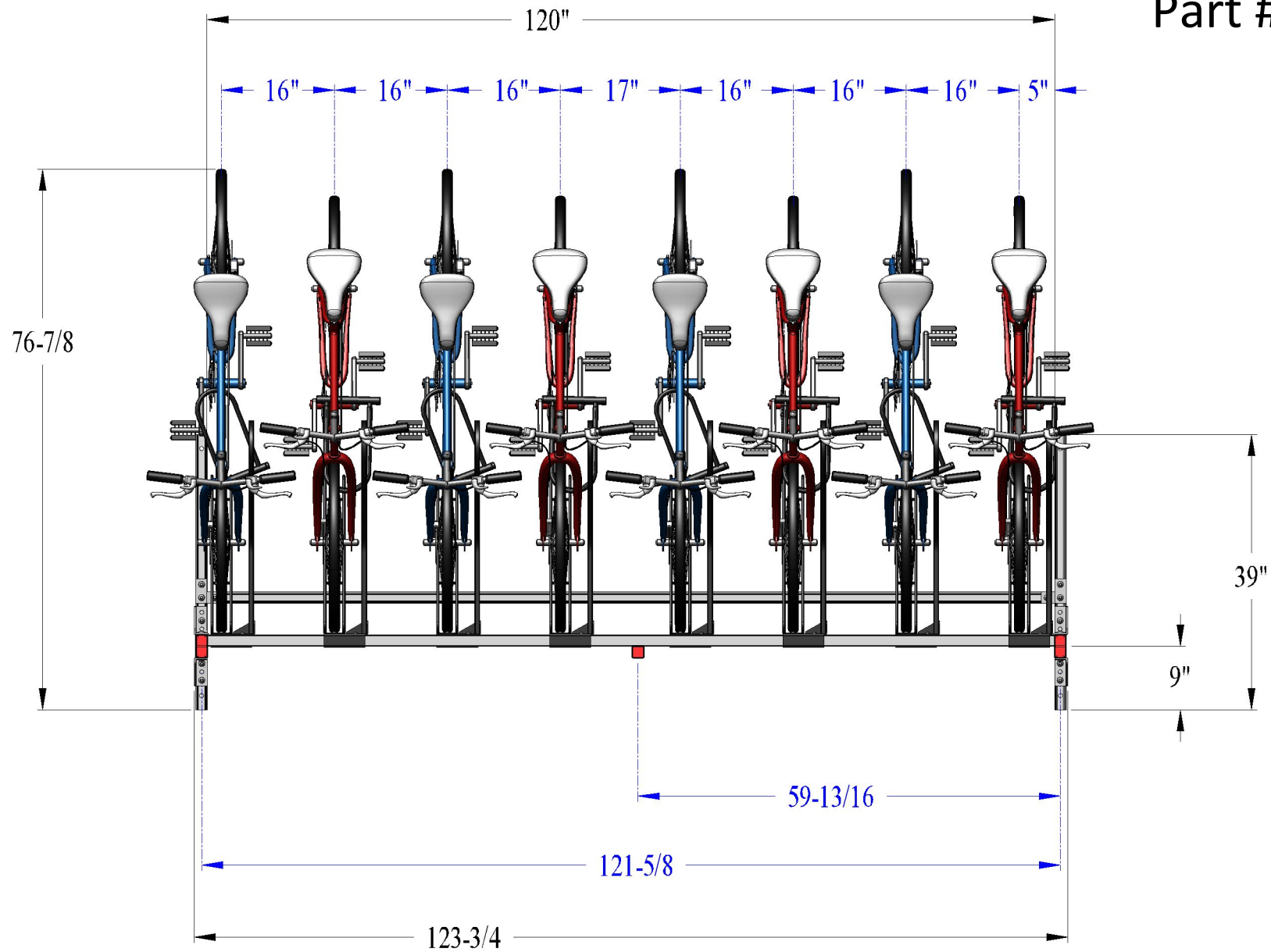

Bike Stall {8-Bike} U-Strut  
Strut Base {Straight} Master {Top} Dim's

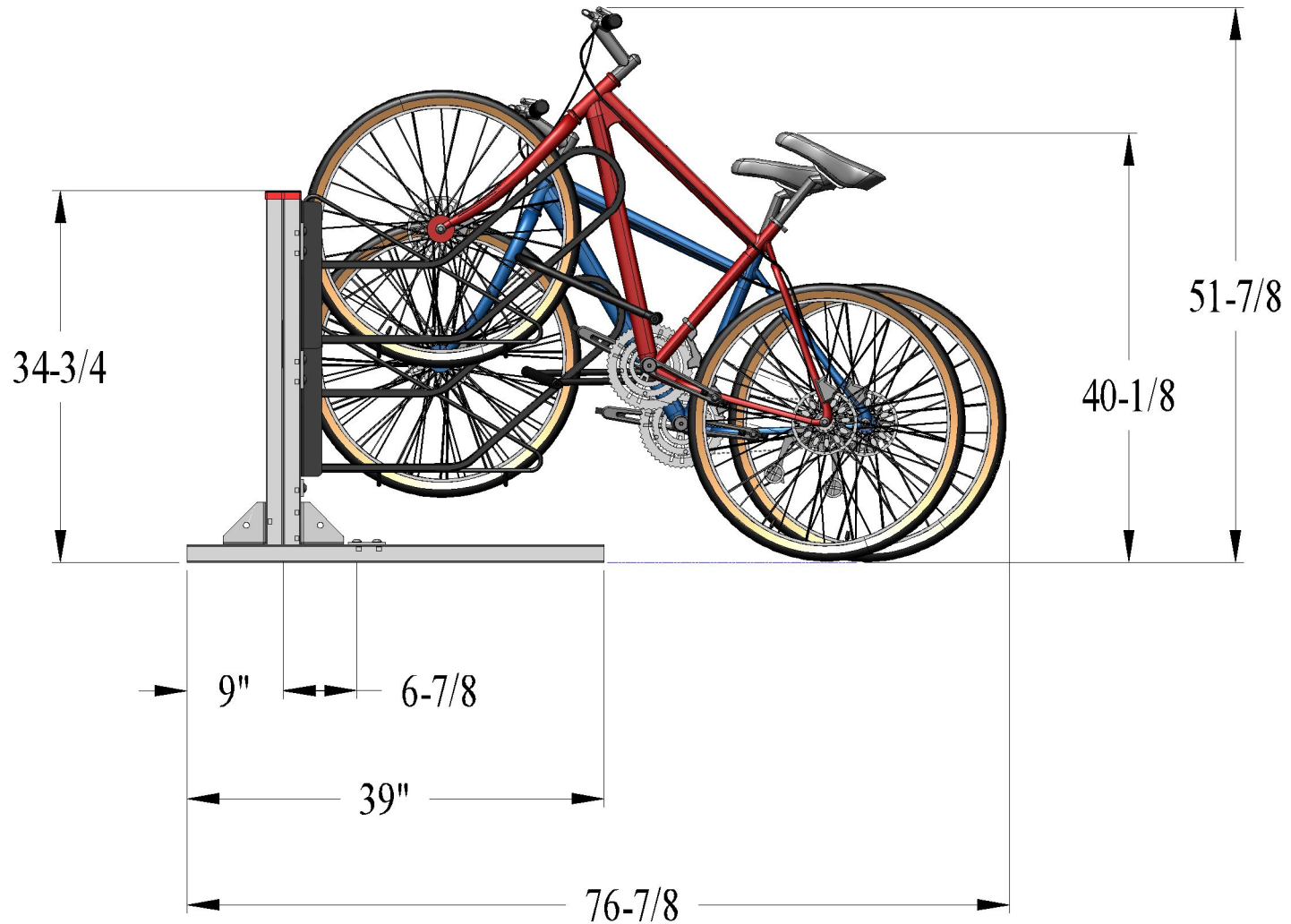

Bike Stall {8-Bike} U-Strut  
Strut Base {Straight} Master {Side} Dim's

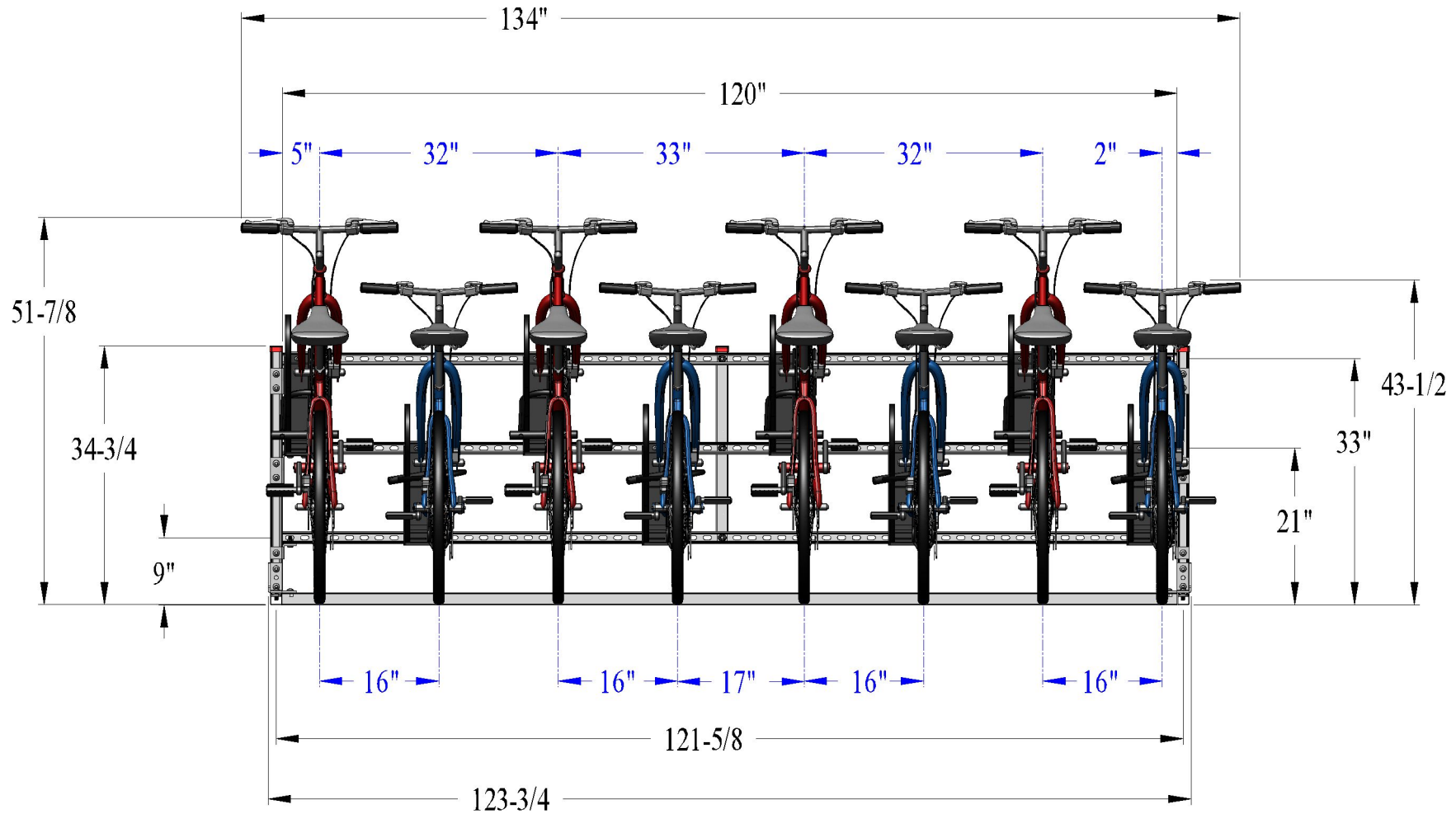

Bike Stall {8-Bike} U-Strut  
Strut Base {Straight} Master {Front} Dim's

Part #17479

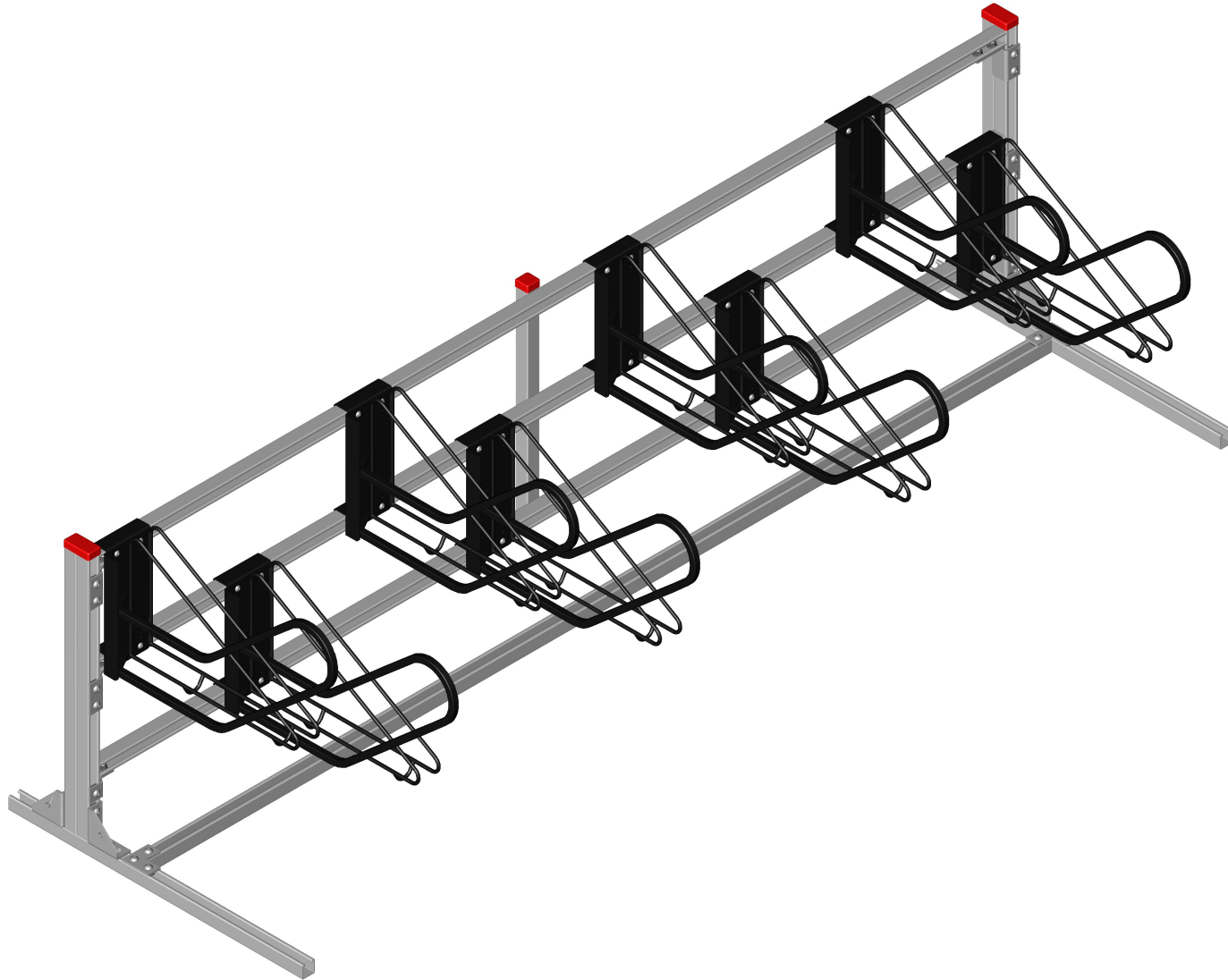

Bike Stall {8-Bike} U-Strut  
Strut Base {Straight} Assembly {Iso}

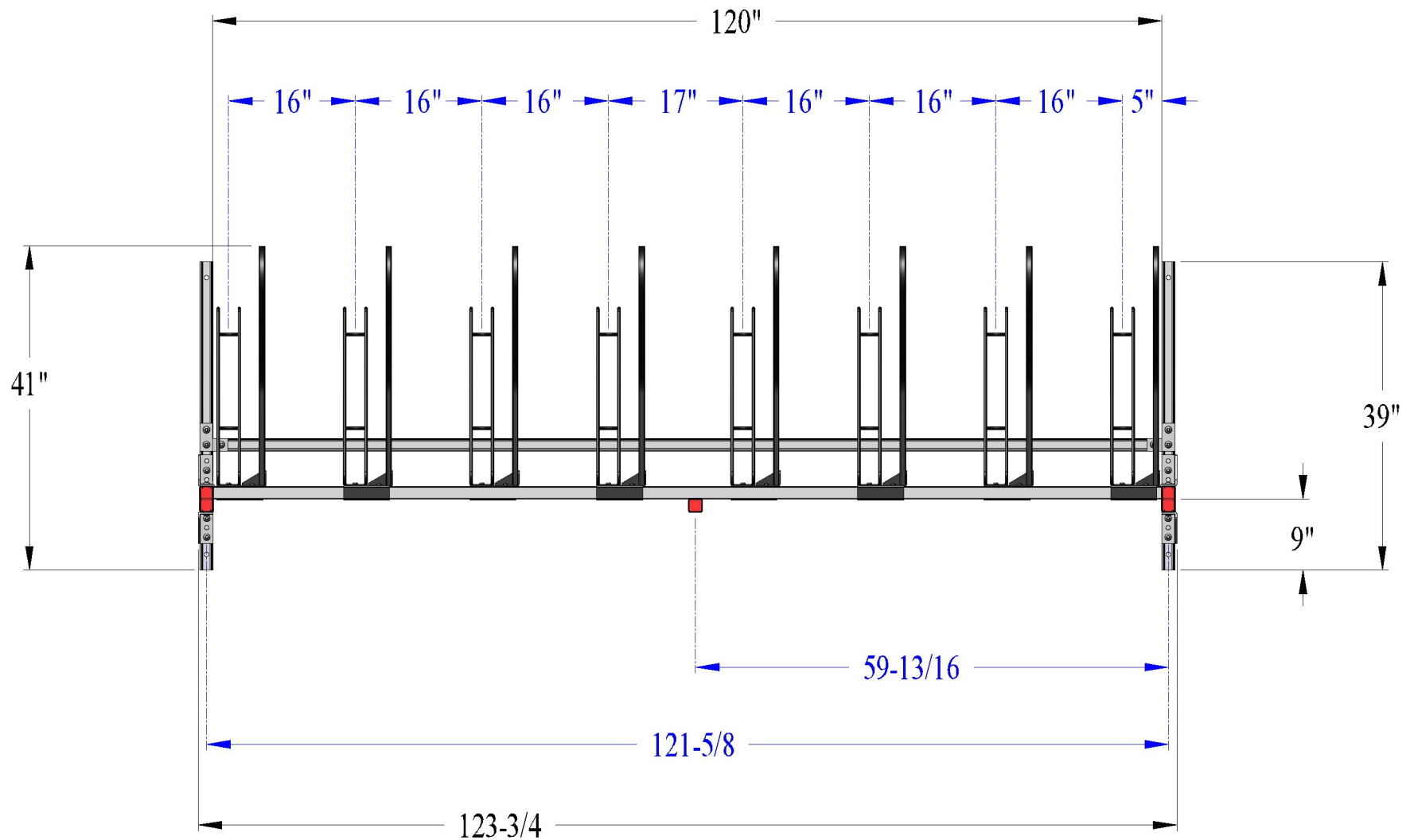

Bike Stall {8-Bike} U-Strut  
Strut Base {Straight} Assembly {Top} Dim's

Part #17479

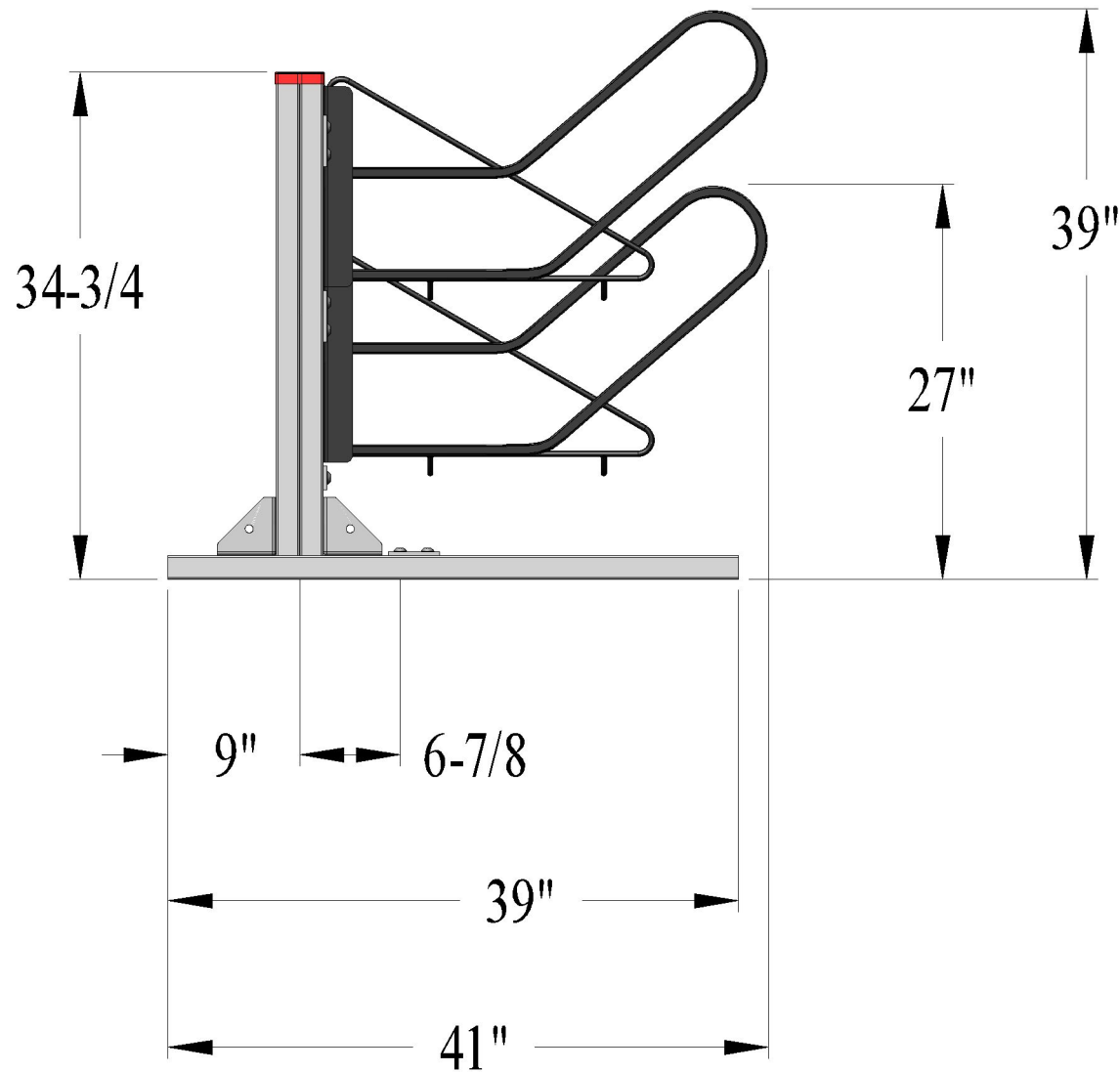

Bike Stall {8-Bike} U-Strut  
Strut Base {Straight} Assembly {Side} Dim's

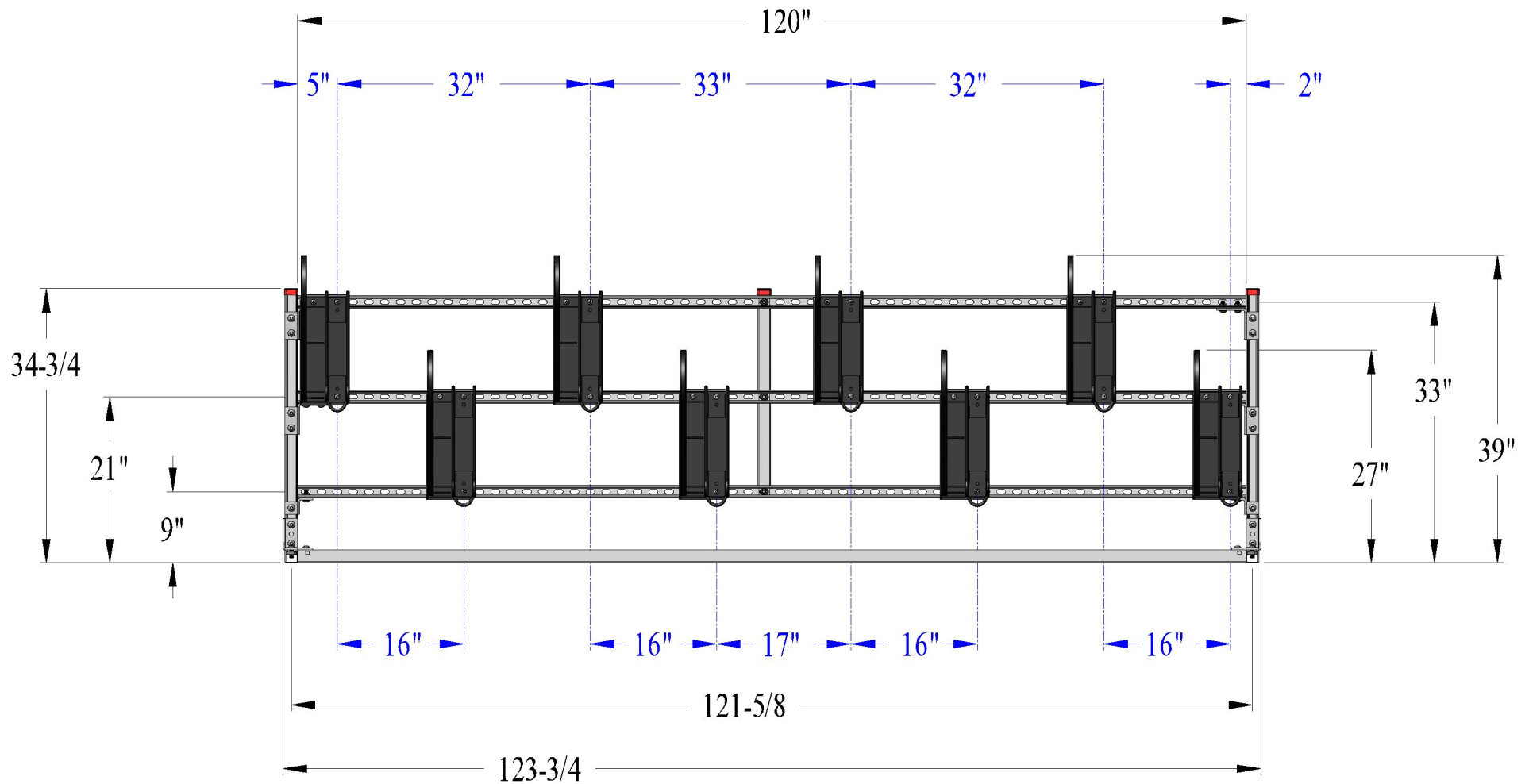

Bike Stall {8-Bike} U-Strut  
Strut Base {Straight} Assembly {Front} Dim's



Part #17479

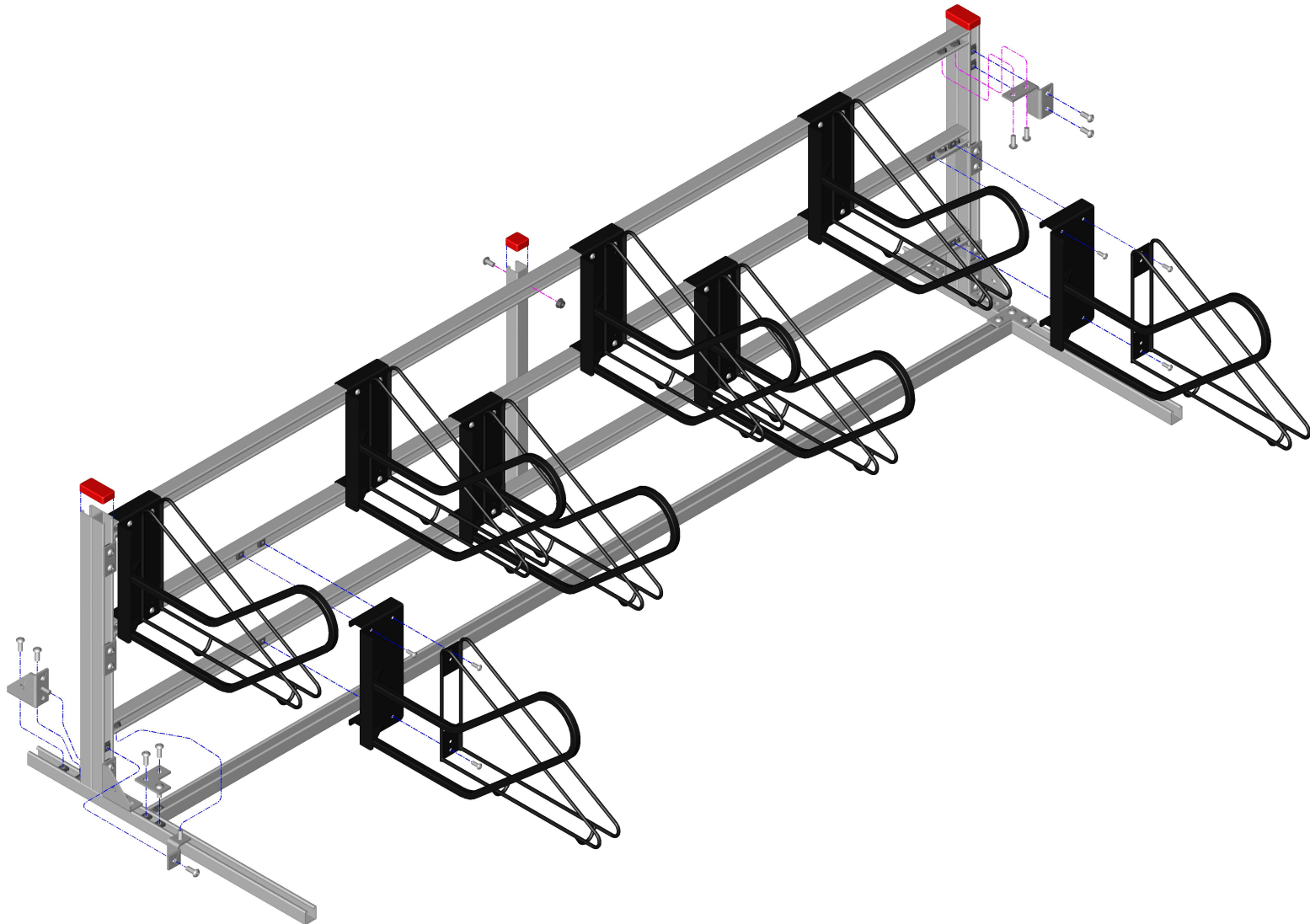

Bike Stall {8-Bike} U-Strut  
Strut Base {Straight} Assembly {Exploded}

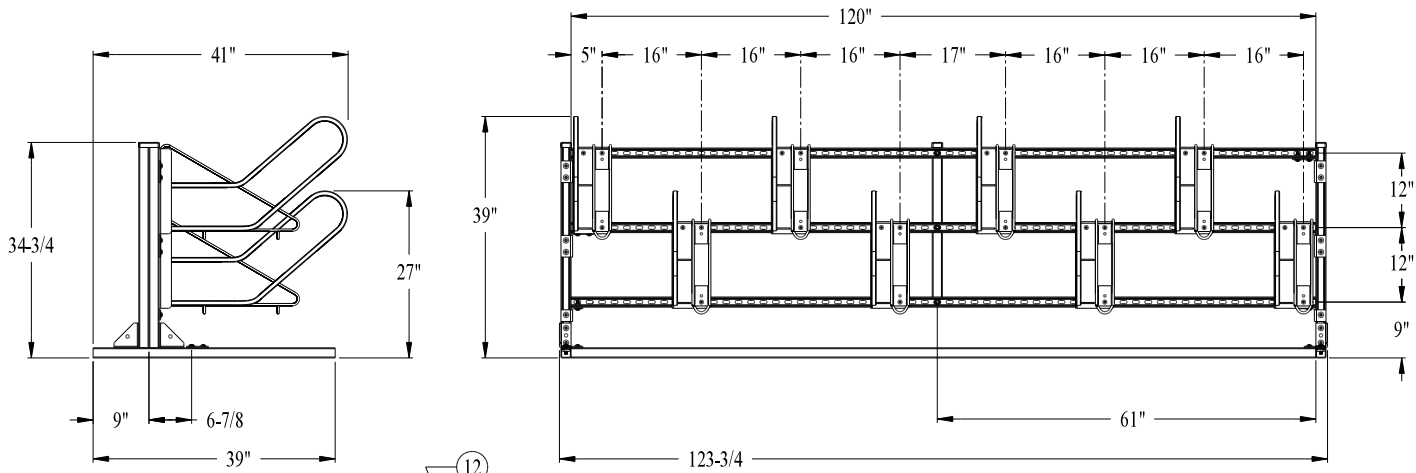

ITEM	QTY	DESCRIPTION	PART NO.
1	3	U-STRUT {SLOTTED} SPANNER x 120" LG.	17470
2	13	3/8-16NC SERRATED FLANGE NUT {ZINC}	19567
3	1	U-STRUT {PLASTIC} END CAP	17530
4	2	H-STRUT {PLASTIC} END CAP	17551
5	2	H-STRUT {PLAIN} UPRIGHT x 33" LG.	17565
6	52	3/8-16NC STRUT {ZINC} NUT	17525
7	2	LARGE - WING FITTING {LEFT}	17474
8	2	LARGE - WING FITTING {RIGHT}	17475
9	2	U-STRUT {PLAIN} BOTTOM	17523
10	65	3/8-16NC x 1" LG. {TORX} S/S BHCS	12724
11	8	WALL-RACK	17502
12	8	LOCK BAR WELDMENT	17549
13	1	U-STRUT {PLAIN} VERTICAL x 26-1/4" LG.	17471
14	1	SMALL - WING FITTING {LEFT}	17472
15	1	SMALL - WING FITTING {RIGHT}	17473
16	4	U-STRUT ANGLE BRACKET	17529
17	1	U-STRUT {PLAIN} SPANNER x 120" LG.	17594
18	2	ANGLE PLATE	17528

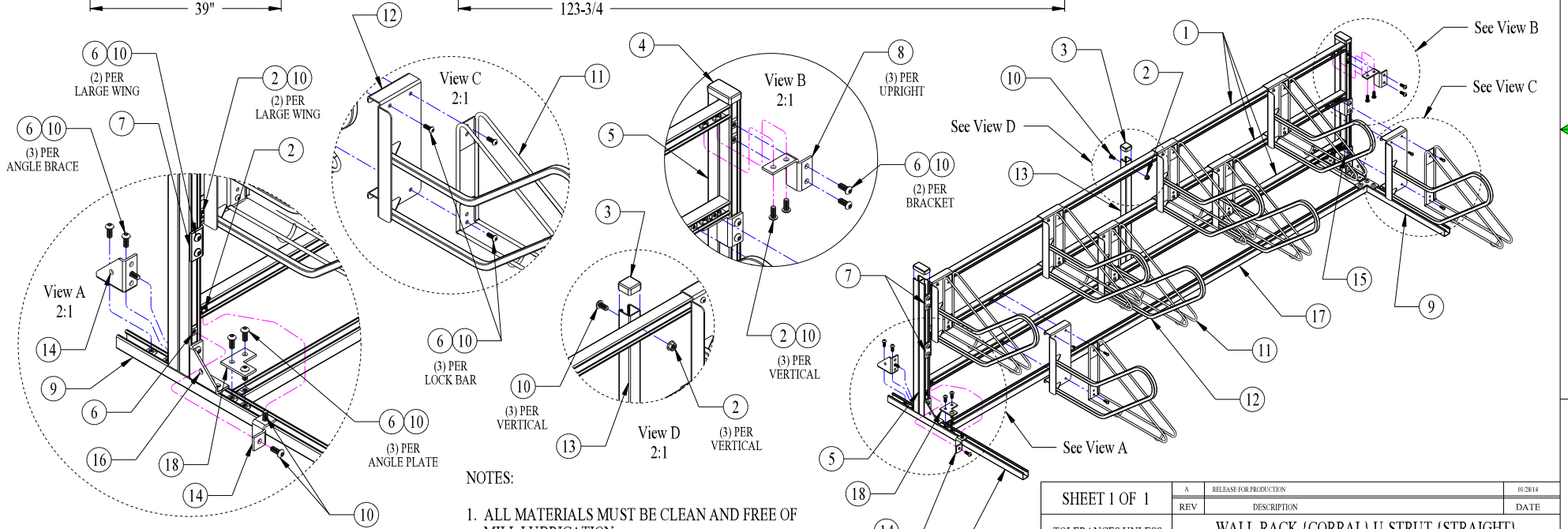

**SINGLE-SIDED  
HIGH DENSITY**

- NOTES:
1. ALL MATERIALS MUST BE CLEAN AND FREE OF MILL LUBRICATION
  2. ANY BLEMISHES OR RUST WILL NOT BE ALLOWED ON COMPLETED PRODUCTS
  3. FOR "TAMPERPROOF" FASTENERS: USE 3/8 S/S TORX (PINNED) BHCS (17590) IN PLACE OF ITEM #10

SHEET 1 OF 1	A	RELEASE FOR PRODUCTION	01/28/14
	REV	DESCRIPTION	DATE
TOLERANCES UNLESS OTHERWISE SPECIFIED: +/-	WALL-RACK {CORRAL} U-STRUT {STRAIGHT}		
	<b>Cycle Safe</b>		
	5211 CASCADE RD SE, SUITE 210 GRAND RAPIDS, MI 49546 www.cyclesafe.com		
	BOB SLYH	01/28/14	
	CHECKED	DATE	
	APPROVED	DATE	
STRUT BASE {&-BIKE} ASSEMBLY	17479		A